

ROTO 40.30 MCSS TECHNICAL DATA

ROTO 40.30 MCSS

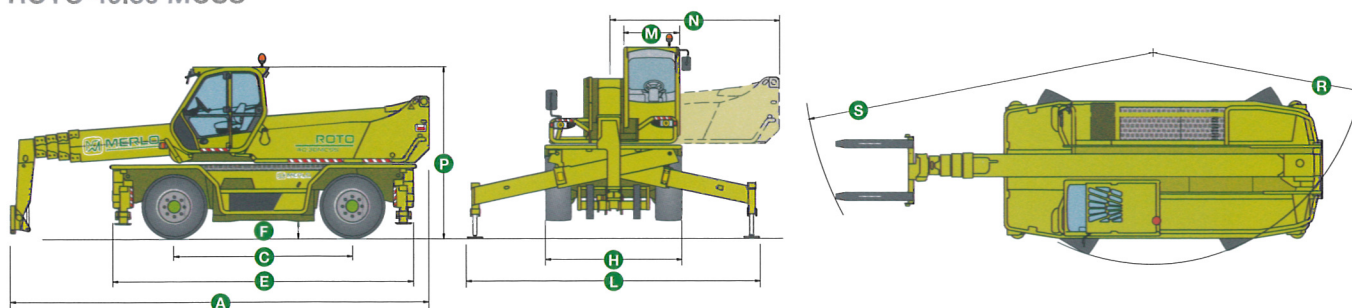

- **Maximum load capacity 4000 kg**
- **Maximum lift height 29.5 metres**
- **Continuous turret rotation** achieved through a Merlo electro-hydraulic central rotary coupling
- **The cab can be tilted by up to 18 degrees** to offer an unequalled view at maximum height
- **Cab steel frame complying with the international ISO 3449 Level II FOPS (Falling Object Protective Structure) standard**
- **Pneumatic suspension seat**
- **Electronic joystick controls**
- **Steering wheel tilt adjustable by up to 16 degrees**
- **Merlin system (Merlo Local Interactive Network)** providing a completely new way to automatically manage all the operating parameters and safety functions
- **MCSS system (Merlin Continuous Slew Safety)** adjusting automatically the load diagram to suit the stabiliser position chosen by the operator
- **Stabilizers with independent extension and jacking**
- **Hydropneumatic suspension** ensuring maximum driving comfort and stability when operating on tyres, by levelling the machine
- **Iveco turbo intercooler 6 cylinder engine, delivering 129 kW (175 CV)**
- **Hydrostatic transmission** utilising variable displacement motor and pump
- **Load-sensing hydraulic pump**
- **Maximum speed 40 kph**

DIMENSIONS	40.30 MCSS
A (mm)	7560
C (mm)	3200
E (mm)	5540
F (mm)	380 ⁽¹⁾
H (mm)	2490
L (mm)	5275
M (mm)	995
N (mm)	3000
P (mm)	3100
R (mm)	4450
S (mm)	6700

CHARACTERISTICS AND PERFORMANCE	40.30 MCSS
Total weight unladen, with forks (kg)	19200
Maximum load capacity (kg)	4000
Maximum lift height (m)	29.5
Maximum forward reach (m)	25.5
Lift height at maximum load capacity (m)	19.4
Forward reach at maximum load capacity (m)	10.5
Load capacity at maximum height (kg)	1500
Load capacity at maximum forward reach (kg)	400
Turret rotation (degrees)	Continuous
Engine (make/cylinder)	Iveco/6
Tier 3 engine power (kW/HP)	129/175
Fuel capacity (l)	150
Speed in the 1 st gear (kph)	16
Speed in the 2 nd gear (kph)	40
Load-Sensing hydraulic system (bar-l/min)	240-124
Hydraulic oil capacity (l)	160
Electrical circuit (V)	12
Battery (Ah)	160
Hydraulically controlled stabilizers	● ⁽²⁾
Hydropneumatic suspension	●
Cab compliant with FOPS standards	●
Tilting cab	●
Merlin electronic control system	●
Electro-mechanical joystick controls	-
Electronic joystick controls	●
Tac-Lock attachment coupling	● ⁽³⁾
Auxiliary boom hydraulic service	●
Two floating forks (1,200 mm long)	●
Hydrostatic transmission	●
Hydrostatic oil capacity (l)	12
Finger-Touch direction reversing control	●
Permanent four-wheel drive	●
Four wheel steering	●
Service disk brakes on all wheels	●
Automatically locking parking brake	●
Tyres	445/65-22.5
Radio remote control	○
Pneumatic seat	●
Rear differential lock	○
Four cab working lights (2 f. + 2 r.)	○
Manual air conditioning system	○
Roof window wiper	○
Manual battery isolator	○
Front and roof sun shade	○

● Standard. ○ Optional.

Performance figures refer to the machine equipped with forks, operating on stabilizers.

(1) Measured at suspension mid-point (± 65 mm);

(2) Stabilising and levelling can be performed automatically; (3) ZM2 version front tool holder.

**ROTO 40-30 MCSS
FORKS ON STABILIZERS THROUGH 360°**

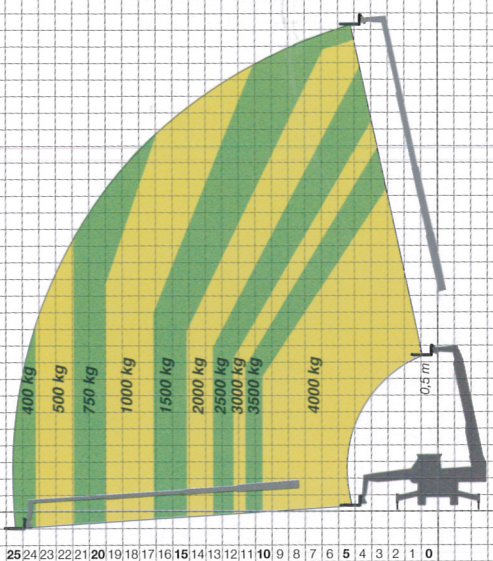

25 24 23 22 21 20 19 18 17 16 15 14 13 12 11 10 9 8 7 6 5 4 3 2 1 0

**ROTO 40-30 MCSS
FORKS ON TYRES - FRONT**

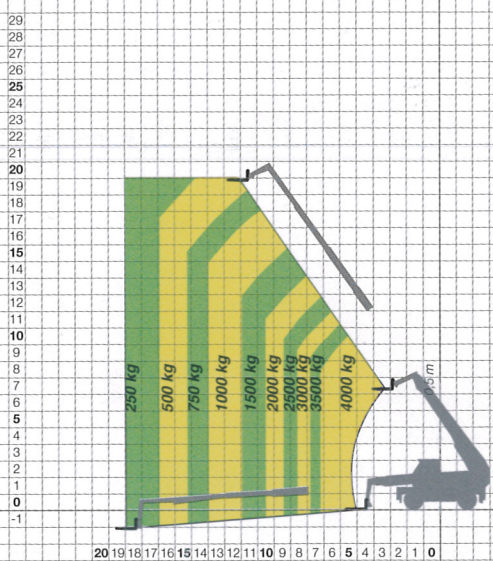

20 19 18 17 16 15 14 13 12 11 10 9 8 7 6 5 4 3 2 1 0

**ROTO 40-30 MCSS
SPACE SYSTEM THROUGH 360°**

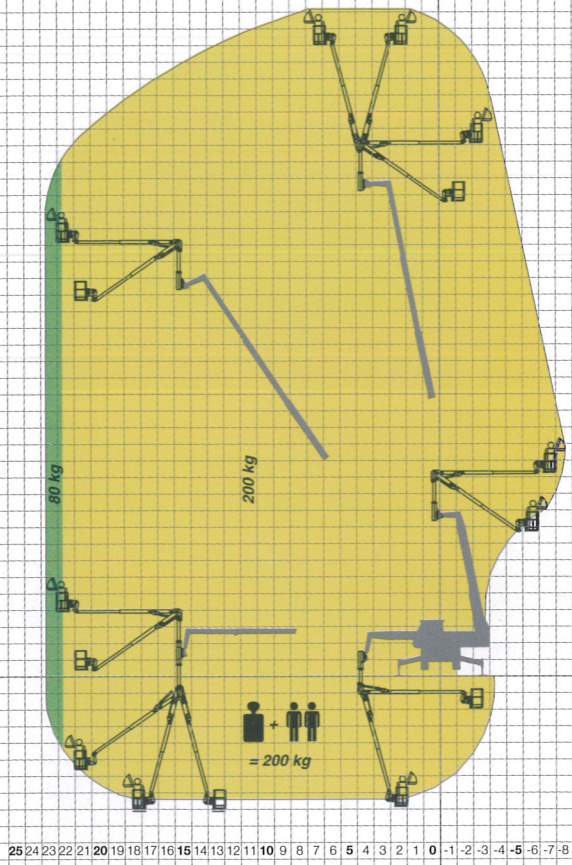

25 24 23 22 21 20 19 18 17 16 15 14 13 12 11 10 9 8 7 6 5 4 3 2 1 0 -1 -2 -3 -4 -5 -6 -7 -8

**ROTO 40-30 MCSS
AERIAL WORK PLATFORM THROUGH 360°**

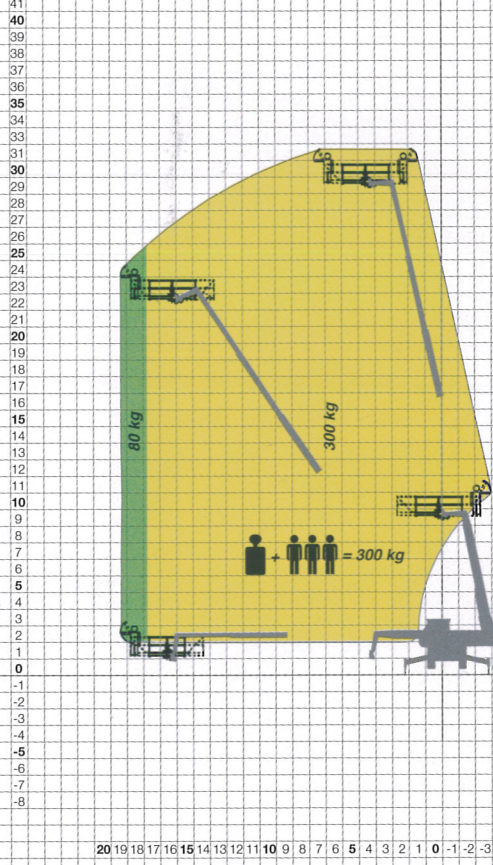

20 19 18 17 16 15 14 13 12 11 10 9 8 7 6 5 4 3 2 1 0 -1 -2 -3 -4